

Content

CN-8033 EtherCAT Network Adapter	2
1 The module overview.....	2
2 Technical Parameters	2
3 Hardware Interface.....	3
4 Wiring	7
5 Process data definition.....	8
6 Configuration parameters definition	9
A Dimension drawing.....	10

CN-8033 EtherCAT Network Adapter

1 The module overview

The CN-8033 EtherCAT I/O module supports standard EtherCAT protocol access. The adapter supports a Max. input of 1024 bytes and a Max. output of 1024 bytes. It supports 32 pcs of extended IO modules.

2 Technical Parameters

Hardware Specification	
System Power	Nominal: 24Vdc, Range: 9-36Vdc Protection: Overcurrent Protection, Reverse Protection: YES
Power Consumption	110mA@24Vdc
Internal BUS Supply Current	Max: 2A@5VDC
Isolation	System Power to Field Power Isolation
Field Power Supply	Power Supply: 22~28V (Nominal 24VDC)
Field Power Supply Current	Max. DC 8A
I/O Modules supported	32 pcs
Wiring	Max.1.5mm (AWG 16)
Mounting Type	35mm Size DIN-Rail
Size	115*51.5*75mm
Weight	130g
Environment Specification	
Operational Temperature	-40~85°C
Operational Humidity	5%~95% RH(No Condensation)
Protection Level	IP20
EtherCAT Parameter	
Protocol	EtherCAT
Process data area	Input Max.1024 Bytes, Output Max.1024 Bytes
Network Interface	2 *RJ45
Speed	10/100Mbps, MDI/MIDX, Full-Duplex
Max.Bus Legenth	100m

3 Hardware Interface

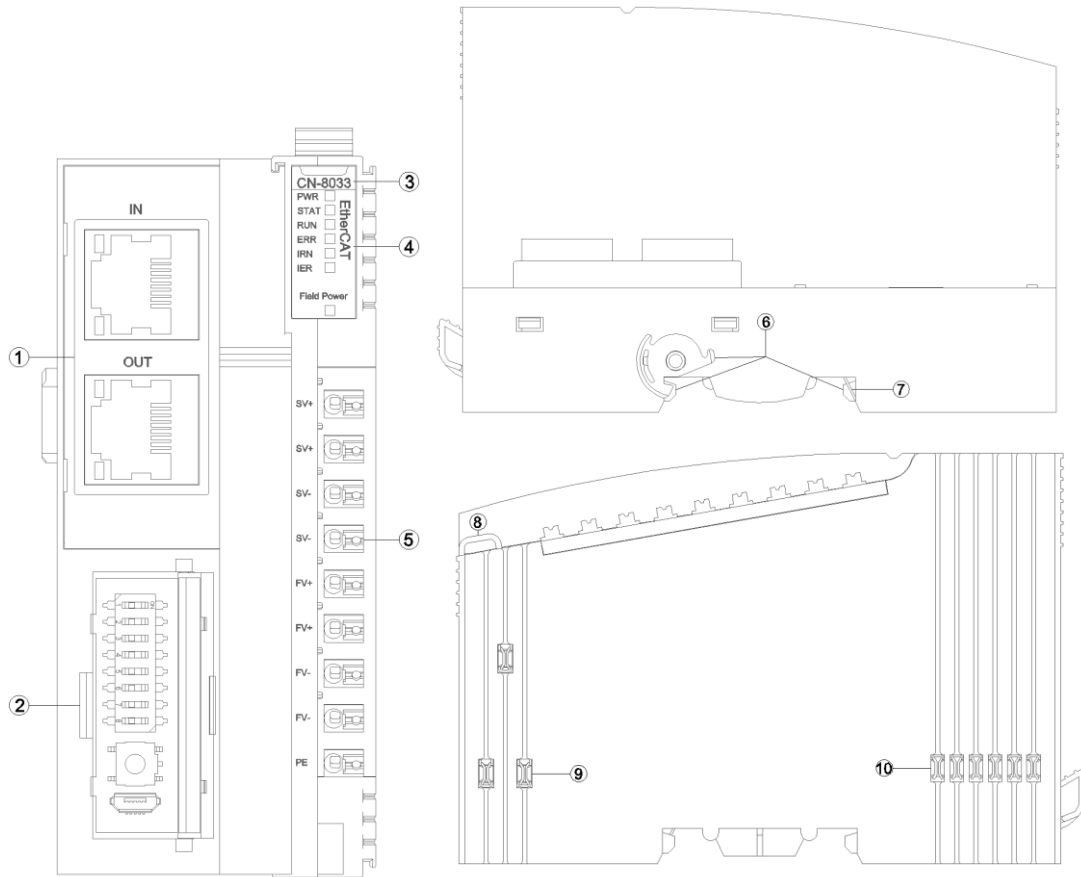

- ① Network Interface
- ② Config Interface
- ③ Module Type
- ④ LED Indicator
- ⑤ Wiring Terminal
- ⑥ Buckle
- ⑦ Grounding Resilient Sheet
- ⑧ Fixed Wiring Harness
- ⑨ Field Power
- ⑩ Internal Bus

3.1 Network Interface

IN is the input interface of EtherCAT, OUT is the output interface of EtherCAT, and it support switch function with 10Mbps and 100Mbps data rates, MDI/MID-X auto crossover.

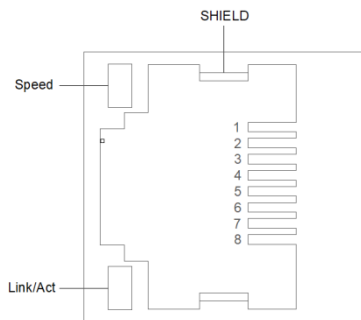

Speed: Network Speed LED Indicator (Green)

ON:100M

OFF:10M

Link/Act: Link State, Active State (Orange)

ON: Link UP

OFF: Link DOWN

Flash: Active

SHIELD: RJ45 Shield Interface

RJ45 Pin definition

Pin	Definition	Description
1	TD+	Transmitter Signal Positive
2	TD-	Transmitter Signal Negative
3	RD+	Receiver Signal Positive
4	--	--
5	--	--
6	RD-	Receiver Signal Positive

7	--	--
8	--	--

3.2 Configuration Interface

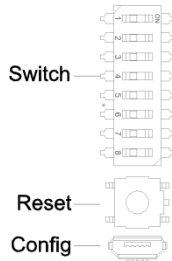

Switch: station alias configuration

When the dial - code switch value is not 0, the dial - code value is station alias, after dialing the code, the site alias will not take effect until the power is turned off and restarted. When the dial - code switch value is 0, using the site alias set by the PLC Master or the site alias in EEPROM memory.

The relationship between the site alias and the dial - code switch value is shown in the following table:

Dial - code switch pin number (ON:1, OFF:0)								Dial - code switch value	Site Alias
1	2	3	4	5	6	7	8		
0	0	0	0	0	0	0	0	0	0
1	0	0	0	0	0	0	0	1	1
0	1	0	0	0	0	0	0	2	2
.
0	1	0	1	0	0	0	0	10	10
.
0	1	1	1	1	1	1	1	254	254
1	1	1	1	1	1	1	1	255	255

Reset: Module reset button. All parameters of the module will be restored to the default value after pressing the button for more than 5 seconds. When the Reset button is pressed, a green LED will light up in the upper left corner of the button.

Config: Configure port, a standard Micro USB interface for configuring device parameters and firmware upgrades.

3.3 LED Indicator

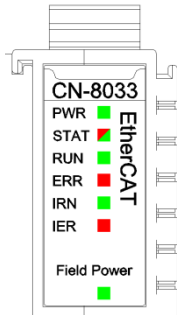

PWR - Power State (RED)	Definition
ON	System Power Normal
OFF	System Power Failure
STAT - Module State LED (RED/GREEN)	Definition
Double Flash (RED)	Module abnormal, has been softly restarted
ON(GREEN)	Operating
Single Flash (GREEN)	Stopping
Flash(2.5Hz) (RED/GREEN)	Upgrading Mode
Flash(10Hz) (RED/GREEN)	Firmware Updating
RUN - Bus running Indicator	Definition
ON	Operating
OFF	Initialization state
Flash(10Hz)	During boot or in the state of BootStrap
Flash(2.5Hz)	Pre-Operational State
Single Flash	Safe Operating State
ERR - Bus Error LED	Definition
OFF	No failure
ON	Application control failure
Flash(10Hz)	Startup Errors
Flash(2.5Hz)	Invalid Configuration
Single Flash	Local error, unsolicited state switch
Double Flash	Watchdog Error
IRN - IO RUN(GREEN)	Definition
ON	IO initialization normal
OFF	IO initialization failure
IER - IO Error (RED)	Definition
OFF	IO communication normal
Double flash	IO communication failure
Field Power - Indicator	Definition
On	On-site power supply normal

Off	On-site power supply abnormal
-----	-------------------------------

4 Wiring

Please note when wiring: for the internal construction, two terminals of SV+ have been short-connected, two terminals of SV- have been short-connected, two terminals of FV+ have been short-connected, and two terminals of FV- have been short-connected. For external it only needs to access one system power supply and one field power supply.

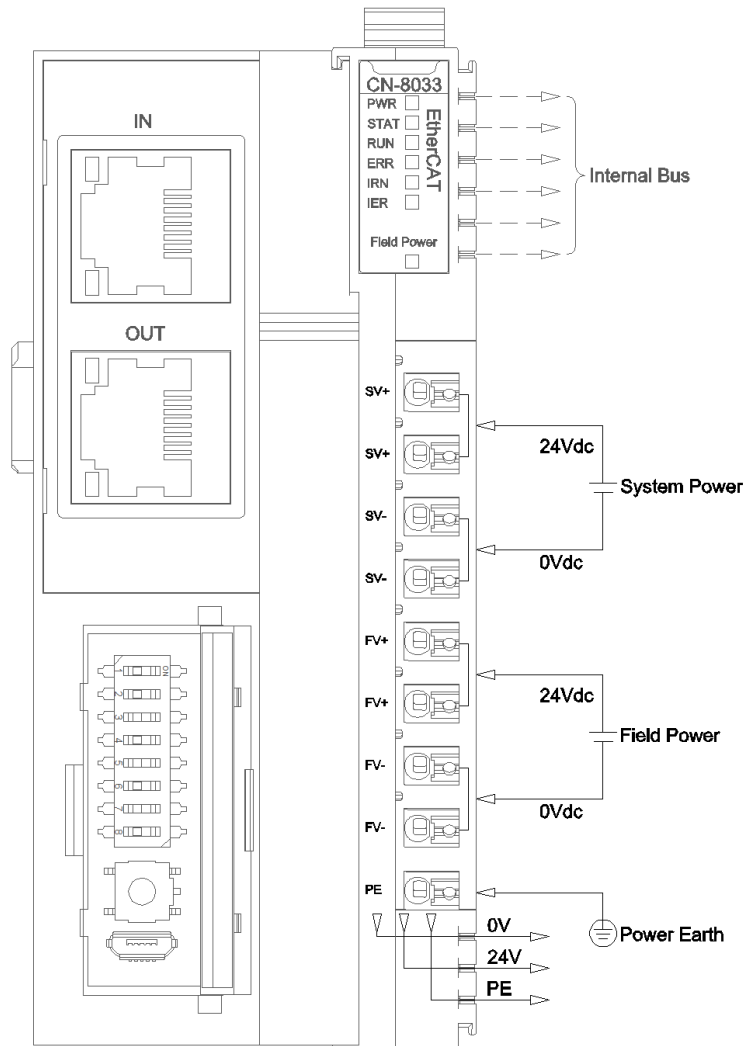

5 Process data definition

5.1 Adapter process data definition

EtherCAT adapter itself has no input/output process data.

5.2 IO module process data mapping

The network adapter reads and writes input and output process data of IO module in real time through the internal bus, and its data mapping model is shown as follow:

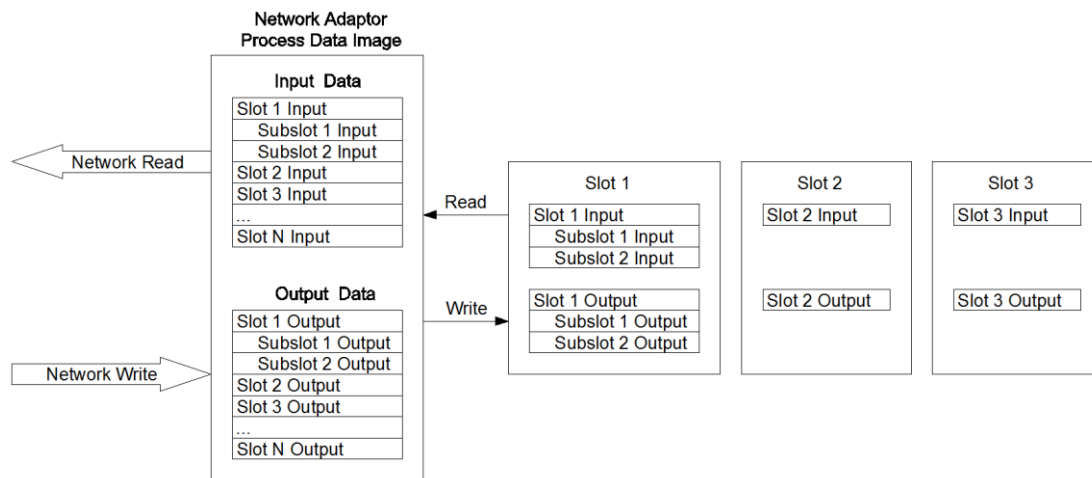

The maximum number of input bytes of the EtherCAT network adapter is 1024 bytes, and the maximum number of output bytes is 1024 bytes.

6 Configuration parameters definition

Configuration parameters									
Bit No	Bit 7	Bit 6	Bit 5	Bit 4	Bit 3	Bit 2	Bit 1	Bit 0	
Byte 0	Reserved					Fault Action for Output	Fault Action for Input	Source of Config Data	

Data description:

Source of Config Data: Parameter configuration mode (Default: 0)

0: Configured software configuration

1: Field Bus configuration

Fault Action for Input: Input fault handling mode, when IO module is offline, the adapter will process IO module input data according to this mode. (Default: 0)

0: Hold Last Input Value

1: Clearing Input Value

Fault Action for Output: Output fault handling mode, when the fieldbus is offline the adapter will process the IO module output data according to this mode.

(Default: 0)

0: Hold Last Output Value

1: Clearing Output Value

A Dimension drawing

