

cMT-iV5 series

Installation Instruction

1 Installation and Startup Guide

This document covers the installation of cMT-iV5, for the detailed specifications and operation, please refer to Brochure and EasyBuilder Pro User Manual.

Install Environment:

Electrical Environment	The cMT-iV5 Series has been tested to conform to European CE requirements. This means that the circuitry is designed to resist the effects of electrical noise. This does not guarantee noise immunity in severe cases. Proper wire routing and grounding will insure proper operation.
Environmental Considerations	<ol style="list-style-type: none"> (1) Make sure that the units are installed correctly and that the operating limits are followed. Avoid installing units in environments where severe mechanical vibration or shocks are present. (2) Do not operate the unit in areas subject to explosion hazards due to flammable gases, vapors or dusts. (3) Do not install the unit where acid gas, such as SO₂ exists. (4) This device should be mounted in the vertical position and for use on the flat surface enclosure. (5) Conform to UL508 (ISBN 0-7629-0404-6) machine safety for use in Pollution Degree 2 Environment.

2 Unpacking the Unit

Unpack and check the delivery. If damage is found, notify the supplier.

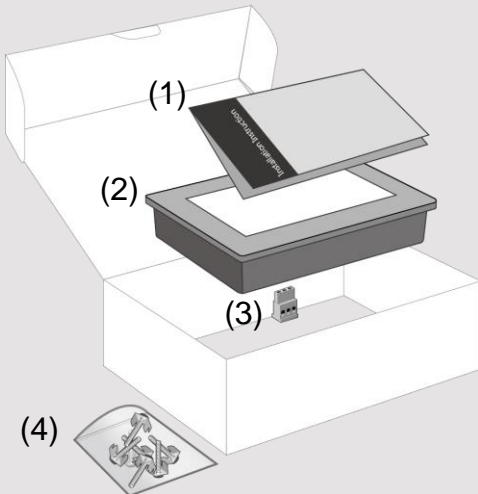

NOTE:

Place the unit on a stable surface during installation. Dropping it or letting it fall may cause damage.

(1) Installation Instruction, 2-sided A4 *1

(2) Human Machine Interface *1

(3) Power Connector *1

(4) Brackets & Screws *1 pack

The packing box can be transformed into an HMI stand. Please follow the steps to make the stand.

1. Remove the center of the box cover along the perforated line.
2. Pull the two inner flaps.
3. Press down along the perforated line inside the box.
4. Complete the stand as shown.

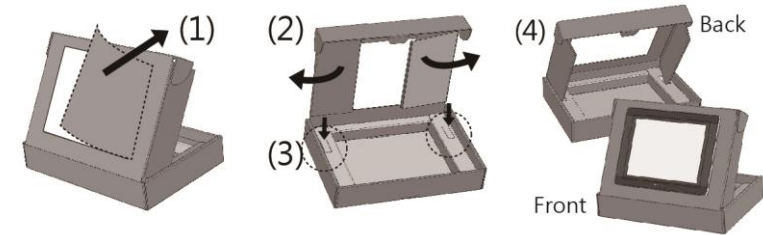

3 Installation Instructions

Secure the operator panel in position, using all the fastening holes and the provided brackets and screws. Screw Torque: 2.6 ~ 3.9 lbf.in. (For reaching waterproof effect and preventing the panel from being deformed.) Panel Cutout: 250 mm x 192 mm

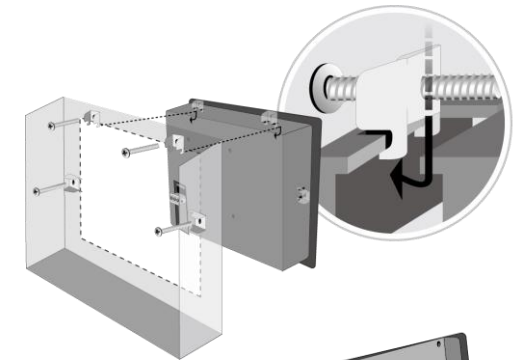

4 Power Connections

NOTE:

Connect positive DC line to the '+' terminal and the DC ground to the '-' terminal.

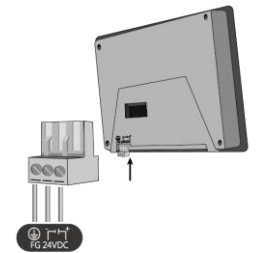

5 System Settings

Connect cMT-SVR, router, and cMT-iV5 via RJ-45 Ethernet cable. Launch cMT Viewer on cMT-iV5, find the cMT-SVR and use the default password "111111" to log in and configure.

cMT-SVR Ethernet Ports:

Ethernet 1: DHCP

Ethernet 2: 192.168.100.1



6 Information

Tap Setting > Information to view the Machine type, HMI name, IP address, Subnet mask, Gateway, Mac address, App. version, and OS. version.



7 General & Language

Tap Setting > General to adjust screen brightness and audio volume by dragging the scrollbars.

Tap the key icon  to change the password.

Tap the direction icon  to change the display direction.

Tap Language to select an interface language.

Tap Input Method to add international keyboards.



8 Time/Date & Network

Tap the lock icon , enter the password and click OK, the Time/Date and Network setting tabs will be enabled.

In Network tab, enable [Obtain an IP address automatically] or manually enter IP address, Subnet mask, Gateway, and DNS.



CAUTION



Power

NOTE: Make sure that all local and national electrical standards are met when installing the unit. Contact your local authorities to determine which codes apply.

The unit can be powered by DC power only, voltage range: 24±20% Volts DC, compatible with most controller DC systems. The power conditioning circuitry inside the unit is accomplished by a switching power supply. The peak starting current can be as high as 2A.



High Voltage

DC voltage sources should provide proper isolation from main AC power and similar hazards.



Emergency Stop

A Hard-wired EMERGENCY STOP should be fitted in any system using cMT-iV5 to comply with ICS Safety Recommendations.



Supply Voltage Condition

Do not power the unit and inductive DC loads, or input circuitry to the controller, with the same power supply. Note: The 24 VDC output from some controllers may not have enough current to power the unit.



Wire Routing

- Power wire length should be minimized (Max: 500m shielded, 300m unshielded).
- Please use twisted pair cables for power wire and signal wire and conform to the impedance matching.
- If wiring is to be exposed to lightning or surges, use appropriate surge suppression devices.
- Keep AC, high energy, and rapidly switching DC power wiring separated from signal wires.
- Add a resistor and capacitor in the parallel connection between the ungrounded DC power supply and the frame ground. This provides a path for static and high frequency dissipation. Typical values to use are 1M Ohm and 4700pF.

DANGER



Hardware Considerations

The system designer should be aware that devices in Controller systems could fail and thereby create an unsafe condition. Furthermore, electrical interference in an operator interface can lead to equipment start-up, which could result in property damage and/or physical injury to the operator. If you use any programmable control systems that require an operator, be aware that this potential safety hazard exists and take appropriate precautions. Although the specific design steps depend on your particular application, the following precautions generally apply to installation of solid-state programmable control devices, and conform to the guidelines for installation of Controllers recommended in NEMA ICS 3-304 Control Standards.



Programming Considerations

To conform with ICS Safety Recommendations, checks should be placed in the controller to ensure that all writable registers that control critical parts of plant or machinery have limit checks built into the program, with an out-of-limit safe shut down procedure to ensure safety of personnel.

GMECIV501_cMT_iV5_Installation_160325

Limited Warranty

This product is limited warranted against defects in design and manufacture. The proven defective product will either be repaired or replaced, at Weintek's discretion. This warranty shall not cover any product which is

- Out of warranty period which is 12 months from the manufacturing month of the HMI products.
- Damage caused by Force Majeure, accident, negligence, improper installation or misuse.
- Product has been repaired or taken apart by unauthorized technicians.
- Products whose identification markings have been removed or damaged.